

Purpose

This technical bulletin provides the basis for the design and specification of safe access infrastructure, clearances and provisions for SA Water's valve chambers (both new and existing). The aim of the bulletin is to provide greater clarity on SA Water's requirements and preferences to improve safety outcomes for works constructed prior to the release of an update to TS 0720.

Background

SA Water owns and operates many types of below-ground infrastructure across South Australia, many of which are valves housed within buried chambers. Although a significant number of valve chambers have historically been installed, a set of standardised criteria has never been consistently implemented, leading to many unique designs and arrangements.

Advances in technology, work health and safety (WHS), operational practices, and maintenance capabilities have developed and changed over the last several years; such changes have yet to be formally incorporated within SA Water's Technical Standards, guidelines or drawings.

With continuing network growth, the number of valve chambers across the state is expected to escalate. Historic/existing valve chambers which require major maintenance must also be reassessed against modern safety standards, and subsequently remediated/modified accordingly. There is a need to standardise safe access requirements for both new and existing valve chambers to provide consistent benefits to stakeholders, customers, people and communities.

Current Situation

Technical Standard TS 0720 (Access Infrastructure for Water Tanks) currently only encompasses access infrastructure for water tanks. SA Water recognises that many other critical assets, further to water tanks, require clarification as to SA Water's safe access requirements/preferences.

In an effort to capture these requirements/preferences, SA Water intend to update TS0720 to include generalised criteria applicable to all assets, as well as specific requirements for valve chambers, elevated liquid storage structures, wet wells and maintenance holes.

Actions

Updating Technical Standards

SA Water is currently taking the opportunity to revise and make updates to the existing TS 0720 (Access Infrastructure for Water Tanks), with the aim to expand the document to encompass other SA Water assets common across the network.

This work is expected to take approximately 12 months, with release expected in the first half of 2024.

Providing Interim Guidance

To reduce confusion and rework regarding upcoming updates, this technical bulletin forms an interim document until such time that a new version of TS 0720 has been finalised. This technical bulletin specifically focuses on general requirements for valve chambers, both new and existing. This technical bulletin also focuses on typical valve chamber arrangements but does not necessarily account for valve chambers housing complex infrastructure.

Below-ground valve chambers associated with submersible sewage pumping stations (SCM Section M) are specifically excluded from the scope of this technical bulletin.

1 Valve Chamber Access

This technical bulletin outlines SA Water's preferences/requirements for safe access infrastructure to both the exterior and interior of a valve chamber.

Proposed variations to the following requirements shall be submitted and approved in advance, in writing, via the Technical Dispensation Request Form (TDRF).

1.1 General Requirements

The following general requirements for valve chambers shall be adopted, as a minimum, for all new installations and/or modifications of existing infrastructure:

- Permanent access infrastructure shall preferably be incorporated, as required, to allow external access to the exterior of the valve chamber (Refer to Section 1.2).
- No permanent access infrastructure shall be installed within the valve chamber interior, except for multi-level chambers (Refer Section 1.3).
- Permanent edge protection is not required where chamber height above surrounding ground does not exceed 300mm.
- Anchor points and fall arrest PPE are not permitted to be used as the primary means of permanent access.

1.2 External Access

The area immediately around all chambers are to be made as safe as reasonably practicable for all people who may approach, work on, or work around the chamber.

1.2.1 Chamber Height (Above-Ground)

For fully buried valves, the optimum chamber height above ground shall be 300 mm for the following reasons:

- Provide adequate barrier for surface water.
- Eliminate the need for edge protection for the valve chamber.
- Provide a barrier against which embers and debris accumulates.

For chamber height greater than 300mm above the surrounding ground, action should be taken to either:

- Install AS 1657-compliant edge protection (perimeter guardrails, etc.) and access infrastructure (step/rung ladder, intermediate step, etc.) to access the top of the chamber.
- Raise the surrounding ground level to reduce the difference in height, in accordance with AS 1657 (see excerpt below in Figure 1).
- Fully or locally lower the height of the chamber wall

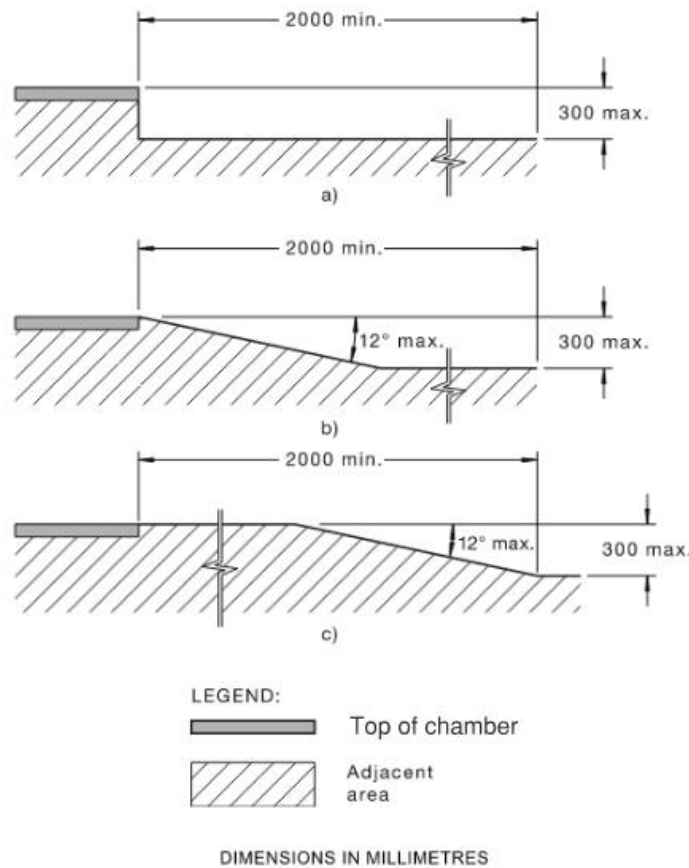

FIGURE 5.2 TYPICAL PROVISIONS OF CLAUSE 5.4.1 WHERE NO GUARDRAIL IS NEEDED

Figure 1: AS1657 Figure 5.2 Excerpt

1.2.2 Valve Operation

Access points and/or extended spindles shall be provided to allow operation of valves from outside (above) the chamber cover.

Consideration should be given to preferred SA Water methodologies for operation of valves, including providing stops and/or mounting brackets for any mechanised valve operating tool.

Valve spindles should not sit proud of the cover, so as to avoid creating a potential tripping hazard. Where the spindle hole may need to be greater than 100mm in diameter, a removable cover/grate to the spindle hole should be provided.

1.3 Internal Access

1.3.1 General Requirements

Except for multi-level chambers (Refer Section 1.5.5), no permanent access infrastructure shall be installed within the valve chamber interior for the following reasons:

- Non-compliant ladder installation to AS 1657 and SA Water working at height standard, in terms of height, installation angle, stiles extension above chamber cover, alignment of top rung with cover and ladder cage.
- Space availability given hatch size and pipework arrangements.
- The unknown condition of the ladder and its fixings to wall given the internal humid environment.

- Safety considerations associated with personnel accessing the interior of a valve chamber (ergonomics, falls, engulfment, etc.)

Interior access shall be a planned activity where all safe means of access (scaffold, temporary ladder, etc.) are organised in advance.

Methods of eliminating or substituting the requirement for personnel to access the chamber interior shall be adopted including, but not limited to, the following:

- Where practicable and with approval of Operation, backfilling and/or burying the chamber with an approved backfill material (generally for pipe OD375 or smaller)
- Relocating equipment and instrumentation (i.e. valves, flow meters, etc.) to ground level, through the reconfiguration of pipework, where they are readily accessible without the need to access the interior of the chamber.
- Installing remote methods of operating equipment housed within the valve chamber (i.e. extended valve spindles), allowing operation from the top of the chamber (refer Section 1.2.2)
- Conducting inspections via drone, or other similar Remotely Operated Vehicle (ROV).

Replacement or major refurbishment of equipment and instrumentation are not generally considered to be "regular access". Any activity which will require a project to be set up, or which may require major dismantling of any infrastructure or equipment, shall be considered a planned activity.

1.4 Chamber Cover Design

Valve chamber covers shall be grid mesh grating (steel, aluminium, FRP or similar) which allows line of sight into the chamber for visual inspection purposes only.

Covers for valve chambers:

- Should comply with the requirements of AS 1657.
- Designed for AS 1657 design loads for floors.
- Should typically be designed to span the width of the chamber from wall to wall in maximum 6.0m length and be of manageable sizes to suit the lifting capabilities of Operations and Maintenance.
- Should typically be fully secured such that cover panels cannot be easily opened or moved. Grating shall be preferably secured using proprietary clips/clamps, fastener discs, permanent bolts, or padlock mechanisms.
- Shall preferably incorporate extension spindle access holes to allow valves to be operated without entering the chamber. Refer also Section 1.2.2.
- Where applicable, should have clearly identified safe lifting points.

1.4.1 Grid Mesh's Supporting Steel Beams

Valve chamber grid mesh cover shall be supported on steel beam spaced to suit the spanning capability of the grid mesh and applied design loadings.

The steel beams shall bear directly on the concrete wall, within a pocket, or U-shaped steel bracket face fixed to the concrete wall. In both cases, no positive connection is required. Refer Figure 2 below.

For end span, the grid mesh shall be supported on steel shelf angle fastened to wall, to allow proprietary clips/clamps installation. Rebating concrete wall for this purpose is not accepted.

All steelworks shall be adequately protected against corrosion to achieve a minimum 25 yrs to first major maintenance.



Figure 2: Steel Beam – Wall Connection

1.4.2 Personnel Access Hatch

A lockable chamber access hatch shall be incorporated within the chamber cover design, for personnel access to clean the chamber and/or undertake minor repair works.

To reduce manual handling, hatch material should be aluminium with consideration of dissimilar materials contact.

The access hatch should typically be 750mm min. square and hinged along one edge. The chamber access hatch shall preferably have a dedicated 900mm square landing area, full perimeter guardrails, and a self-closing gate.

An AS 1657-compliant landing area shall be provided adjacent the access hatch.

Securing points or rung cradles shall be provided at the top to allow for the fastening of portable ladders which can be lowered into the chamber.

1.4.3 Drainage Sump's Access Hatch

Where a chamber has a dedicated sump for pumping out water (refer Section 1.5.3), provisions should be made to ensure excess water can be removed from the chamber without needing to remove the cover, or otherwise access the chamber interior.

This may include:

- Provision of a small access point (hinged hatch or similar) directly above a sump in the bottom of the chamber, to allow a submersible pump or hose to reach the sump.
- Provision of hard pipe and couplings to allow connection of a suction pump from ground level.

Access hatch for drainage sump is envisaged to be located in the opposite corner to the personnel access hatch.

1.5 Specific Requirements for New Chambers

1.5.1 Internal Clearances

The layout of pipework within the chamber shall be individually designed such that there is sufficient clearance for operation, maintenance and repair of any particular installation.

Minimum clearances between the chamber and the nearest component are shown below in Table 1.

Table 1: Minimum Internal Clearances¹

Chamber Element	Clearance to Nearest Component
Floor to pipe	500 mm
Non-working side wall	600mm
Working side wall (clear to bypass pipe)	600 mm
End wall to near flange face	900 mm ²
End wall to nearest weld (including welded collar)	600 mm
Head room under support beams	2000mm

¹ Where possible, the footprint of the valve chamber is to be less than or equal 15m², and less than 4m depth to comply with Development Approval exemption Schedule 4. Otherwise, Development Approval is to be sought.

²The dimension specified allows for pipework or fitting removal by cutting and banding the pipework using welded collar.

1.5.2 Location

In road reserves the chamber shall preferably be located in the road verge to allow:

- Safer personnel access, away from the traffic.
- Minimum interruption to traffic.

In other locations, including reservoir or tank sites, the chambers should preferably be located:

- To allow for future expansion of the facilities.
- To allow for vehicle access to all facilities.

1.5.3 Chamber Drainage

Chambers shall be provided with drainage facilities in the form of a watertight sump integrated with the concrete floor.

The sump should be large enough to hold some debris and the suction of a portable pump. A 450mm square by 300mm deep sump is considered acceptable.

All sumps shall preferably be fitted with a removable grate/lid. Consideration shall be given to allow removal and replacement of grate/lid from the exterior of the chamber at ground level (i.e. a lifting chain or similar).

Refer Section 1.4.3.

1.5.4 Chamber Depth

Wherever possible, the overall depth of the valve chamber shall be minimised. Installation of deep chambers which require multi-level access arrangements should preferably be avoided.

Where the overall chamber depth exceeds 3000mm, additional access provisions may be required (refer Section 1.5.5).

1.5.5 Multi-Level Chambers

Where the overall depth of the chamber exceeds 3000mm, and all other alternative solutions/modifications have been considered as per this Technical Bulletin, the incorporation of one or multiple internal intermediate working platforms may be adopted.

Platforms shall be sized to allow for all anticipated works and, where deemed necessary, shall incorporate access provisions to the base of the chamber.

Provisions for multi-level chambers shall be made to ensure all equipment and instrumentation is operable from the uppermost working platform. Access to lower platforms shall be appropriately protected by a lockable self-closing gate.

1.6 Safety in Design

Designers are reminded that in applying the requirements of this Technical Bulletin to SA Water projects, they are not absolved of any Safety in Design (per TS 0101 (Safety in Design)), detailed design or statutory obligations to which they may be subject.

Version History

Version	Date	Author	Comments
1.0	24/08/2023	Matthew Davis	Final.
2.0	12/04/2024	Hany Habib	Updated following a workshop with Operations and Maintenance.